



NATIONAL COMPETITIVENESS COUNCIL



DEPARTMENT OF FINANCE



DEPARTMENT OF INTERIOR AND LOCAL GOVERNMENT



DEPARTMENT OF TRADE & INDUSTRY



BUREAU OF INTERNAL REVENUE



SECURITIES AND EXCHANGE COMMISSION



LUNGSOD NG QUEZON



SOCIAL SECURITY SYSTEM



PHILIPPINE HEALTH INSURANCE CORPORATION



PAG-IBIG FUND



LAND BANK OF THE PHILIPPINES



DEVELOPMENT BANK OF THE PHILIPPINES

WELCOME



NATIONAL COMPETITIVENESS COUNCIL



DEPARTMENT OF FINANCE



DEPARTMENT OF INTERIOR AND LOCAL GOVERNMENT



DEPARTMENT OF TRADE & INDUSTRY



BUREAU OF INTERNAL REVENUE



SECURITIES AND EXCHANGE COMMISSION



LUNGSOD NG QUEZON



SOCIAL SECURITY SYSTEM



PHILIPPINE HEALTH INSURANCE CORPORATION



PAG-IBIG FUND



LAND BANK OF THE PHILIPPINES



DEVELOPMENT BANK OF THE PHILIPPINES

DOING BUSINESS MADE EASIER

May 05, 2016 | UP-Ayala Technohub, Diliman, Quezon City



OVERVIEW

FAISAH G. DELA ROSA

Program Officer

National Competitiveness Council

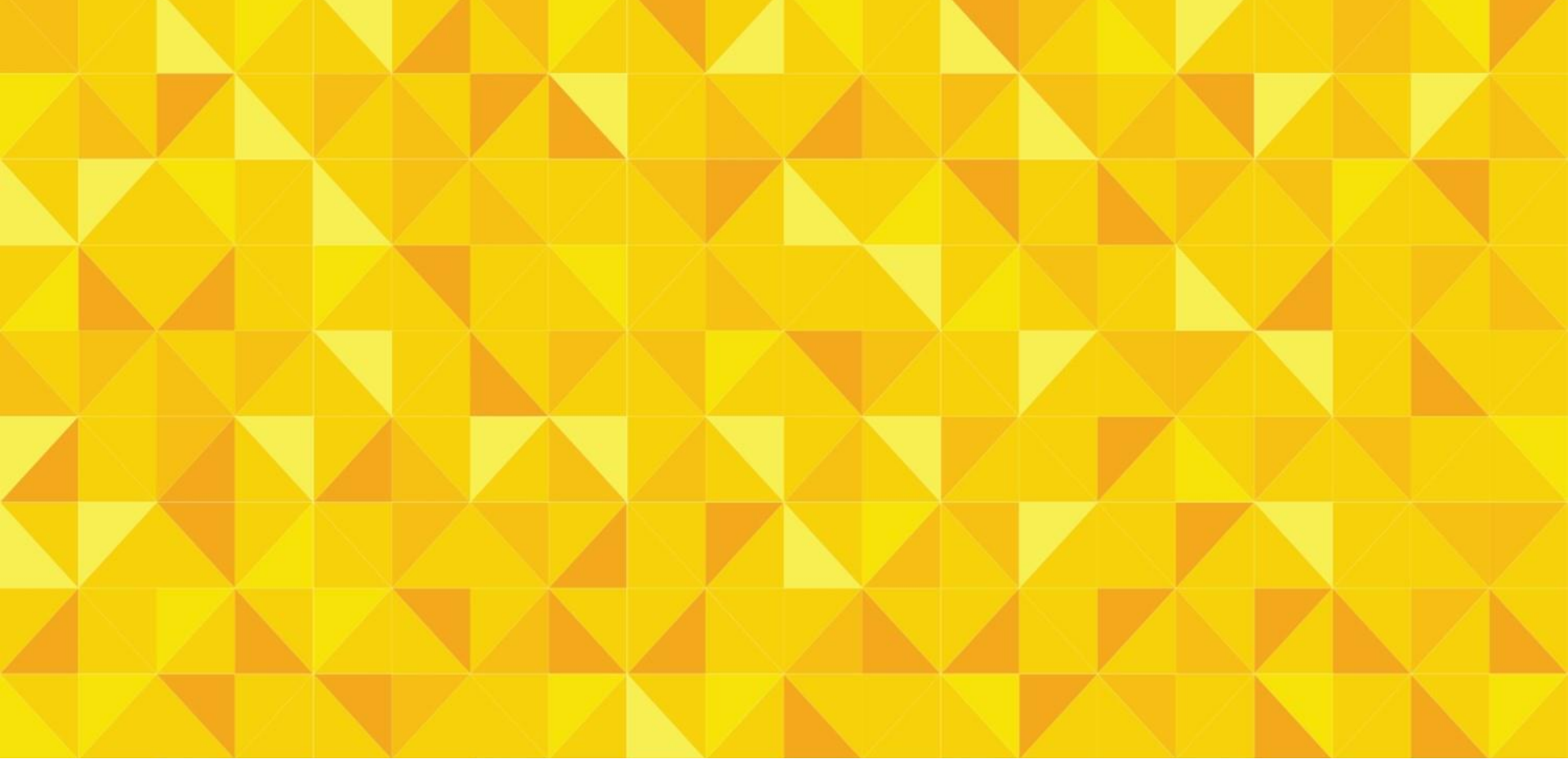

National Competitiveness Council

**VISION AND MISSION
PROGRAMS/PROJECTS**



MANDATE: EXECUTIVE ORDER NO. 44

- Advise the President on policy matters affecting competitiveness of the country
- Promote and develop competitiveness strategies and push for the implementation of an action agenda for competitiveness and link it to the Philippine Development Plan
- Provide inputs to the Philippine Development Plan, Investment Priorities Plan, Export Development Plan
- Recommend to Congress proposed legislation regarding country competitiveness
- Strategize and execute steps to improve Philippine competitiveness.



VISION / MISSION

- A more competitive Philippines
- Instill a Culture of Excellence
- Public-Private Collaboration as a development engine

To build up the long-term competitiveness of the Philippines through:

- Policy reforms
- Project implementation
- Institution-building
- Performance monitoring

MEMBERSHIP

Public Sector Chairman

Sec. Adrian Cristobal, DTI

Members

Sec. Cesar Purisima, DOF

Sec. Ramon Jimenez, DOT

Sec. Armin Luistro, DepEd

Sec. Arsi Balisacan, NEDA

Private Sector Co-Chairman

Guillermo M. Luz

Members

Jaime Augusto Zobel de Ayala, CEO,
Ayala Corporation

Ed Chua, CEO, Shell

Tony Tan Caktiong, Chairman,
Jollibee Food

Lance Gokongwei, CEO, JG Summit



Ayala





WORK PROGRAM

- **Benchmark** against key global competitiveness indices
- **Map** each indicator to the agency responsible
- **Focus** on lowest- indicators
- **Track** city competitiveness and key indicators
- **Working Groups** concentrate on specific projects
- **Link** work to Philippine Development Plan, National Budget, Legislative Executive Development Advisory Council, Cabinet Agenda



PROJECTS

- Working Groups
 - Sectoral focus
- Regional Competitiveness Committees
 - Geographical focus
- Ease of Doing Business Task Force
 - Process improvement focus
- Balanced Scorecards
 - Institutional focus
- Monitoring and Evaluation
 - Customer surveys
- Simplification
 - Regulatory focus



WORKING GROUPS

- Agribusiness and Trade Logistics
- Anti-Corruption
- Budget Transparency Delivery
- Business Permits and Licensing System
- Education and Human Resources Development
- ICT Governance
- Infrastructure
- Judicial System
- National Quality Infrastructure
- National Single Window
- Performance Governance System
- Philippine Business Registry
- Power and Energy
- Services

2015 GLOBAL COMPETITIVENESS REPORT CARD

REPORT	2015 RANK	2014 RANK	2013 RANK	CHANGE	ASEAN RANK	TOP 1/3	PERFORMANCE 4 or 5 years
1. WEF -Global Competitiveness Report	47/140	52/144	59/148	↑ 5	5 of 9	47****	↑ 38
2. IFC- Ease of Doing Business	103/189*	95/189**	108/189	↓ 8	6 of 10	63	↑ 45
3. TI - Corruption Perception Index	95/168	85/175	94/177	↓ 10	3 of 9	58	↑ 39
4. HF - Economic Freedom Index	76/178	89/178	97/177	↑ 13	5 of 9	59	↑ 39
5. WEF- Global Information Technology Report	76/143	78/148	86/144	↑ 2	5 of 9	48	↑ 10
6. WEF - Travel and Tourism Report	74/141	n/a	82/140	↑ 8	5 of 7	46	↑ 20
7. WEF - Global Enabling Trade Index	n/a	64/138	n/a	↑ 8	6 of 10	46	↑ 28
8. IMD -World Competitiveness Report	41/60	42/60	38/60	↑ 1	4 of 5	20	↑ 1
9. WIPO - Global Innovation Index	83/141	100/143	90/142	↑ 17	5 of 8	47	↑ 8
10. WB - Logistics Performance Index	n/a	57/160	n/a	↓ 5	6 of 9	53	↓ 2
11. FFP - Fragile States Index ***	48/178	52/178	59/178	↓ 4	8 of 10	118	↓ 6
12. WEF - Global Gender Gap Report	7/145	9/142	5/136	↑ 2	1 of 9	47****	---

*Ranking based on the 2016 Doing Business Report

**Ranking based on the 2015 Doing Business Report

***Reverse ranking (1 as worst) – Fragile States Index

As of April 2016

**** REACHED THE TOP THIRD

BIGGEST GAINERS

2010-2015



+45

**DOING BUSINESS
REPORT**

No. 103

from No. 148



+38

**GLOBAL
COMPETITIVENESS
REPORT**

No. 47

from No. 85



+39

**ECONOMIC
FREEDOM INDEX**

No. 76

from No. 115



+39

**CORRUPTION
PERCEPTION INDEX**

No. 95

from No. 134

DOING BUSINESS: PHILIPPINE RANKINGS (2011-2016)

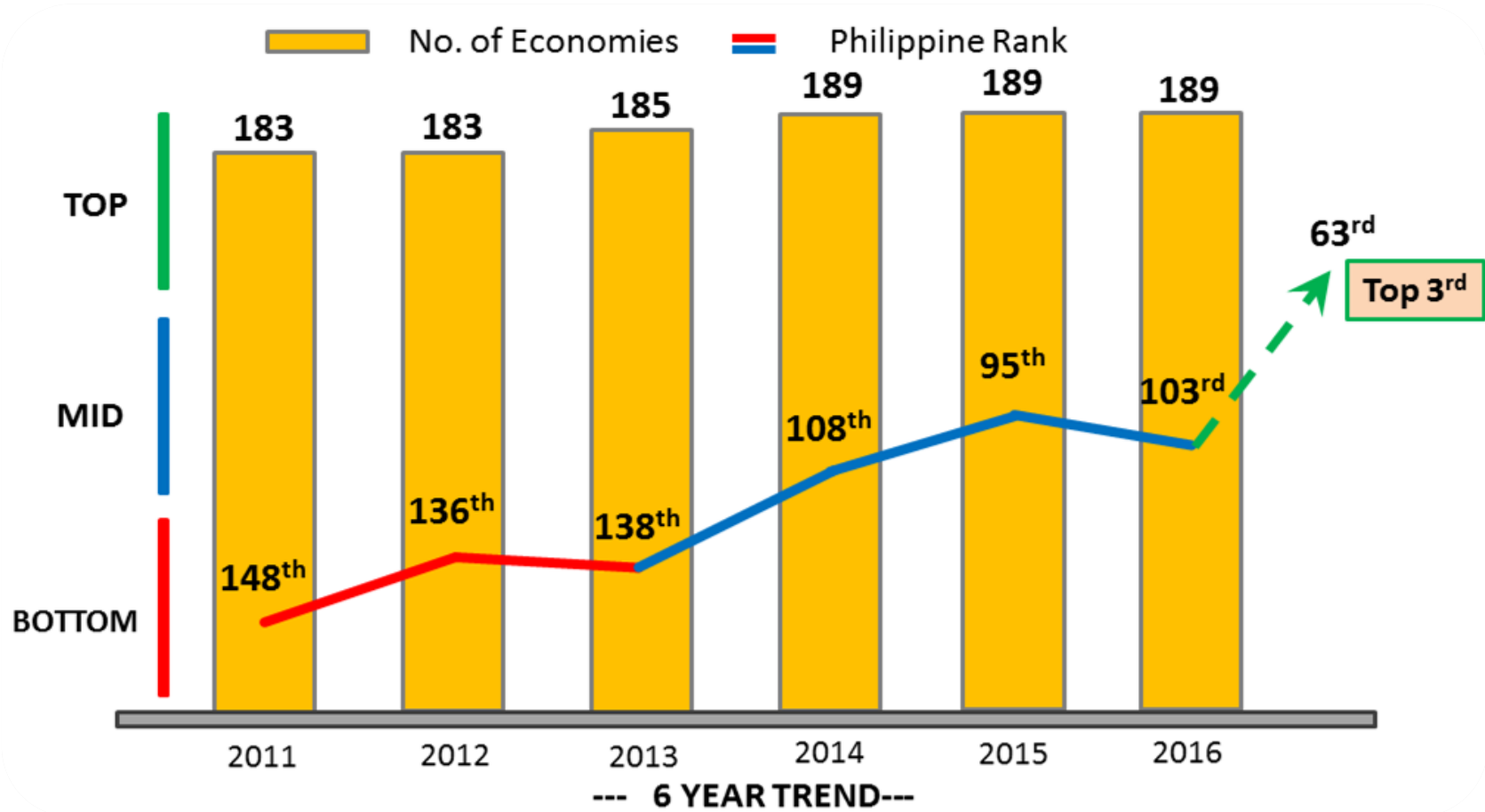

Source: Published DB reports (2011-2016)

DOING BUSINESS INDICATORS PHILIPPINES (2015-2016)

INDICATORS	2016 (189)	2015 (189)	Change 2015- 2016
OVER-ALL RANKING	103	95	↓ 8
1. Starting a Business	165	161	↓ 4
2. Dealing w/ Construction Permits	99	124	↑ 25
3. Getting Electricity	19	16	↓ 3
4. Registering Property	112	108	↓ 4
5. Getting Credit	109	104	↓ 5
6. Protecting Minority Investors	155	154	↓ 1
7. Paying Taxes	126	127	↑ 1
8. Trading Across Borders	95	65	↓ 30
9. Enforcing Contracts	140	124	↓ 16
10. Resolving Insolvency	53	50	↓ 3

Source: Published DB reports (2015-2016)

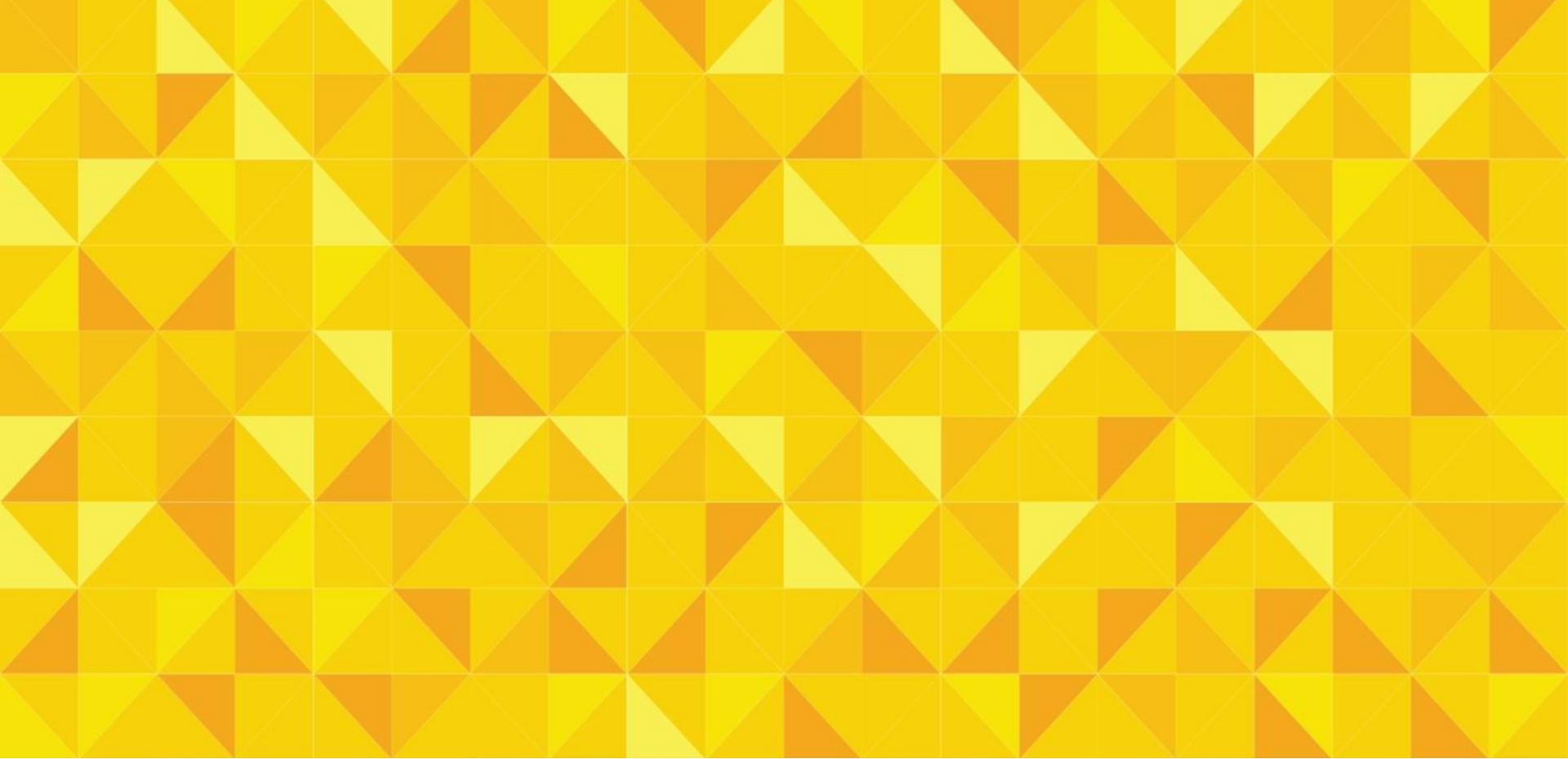

EASE OF DOING BUSINESS

**PROCESS AND AGENCIES
FLOW CHARTS**

STARTING A BUSINESS

Old vs New Procedures

FROM:

16 **29**
STEPS DAYS

2015

TO:

6 **8**
STEPS DAYS

2016



SOCIAL SECURITY SYSTEM



STARTING A BUSINESS

Old Procedures

1 Verify and reserve the company name with SEC
(1 day, Php 40)

2 Deposit Paid in Capital at the bank
(1 day, Php 0)

3 Notarize articles of incorporation and treasurer's affidavit.
(1 day, Php 500)

4 Register the company with SEC and receive pre-registered TIN.
(2 days average, see procedure details)

5 Obtain barangay clearance.
(1 day, Php 500)

6 Pay annual community tax and obtain community tax certificate.
(1 day, Php 500)

7 Obtain business permit from BPLO.
(6 days, see procedure details)

8 Buy special books of account at book-store. (1 day, Php 400)

9 Apply and pay for Certificate of Registration and obtain TIN at BIR.
(1 day, see procedure details)

10 Pay registration fee and documentary stamp taxes
(1 day, see procedure details)

11 Obtain authority to print receipts and invoices from BIR.
(1 day, Php 0)

12 Print receipts and invoices.
(7 days, Php 3,500)

13 Have books of accounts and Printer's Certificate of Delivery stamped by BIR.
(1 day, Php 0)

14 Register with SSS.
(1 day, Php 0)

15 Register with PhilHealth.
(1 day, Php 0)

16 Register with Pag-IBIG.
(1 day, Php 0)

can be completed in **29** days

STARTING A BUSINESS

Agency Flowchart

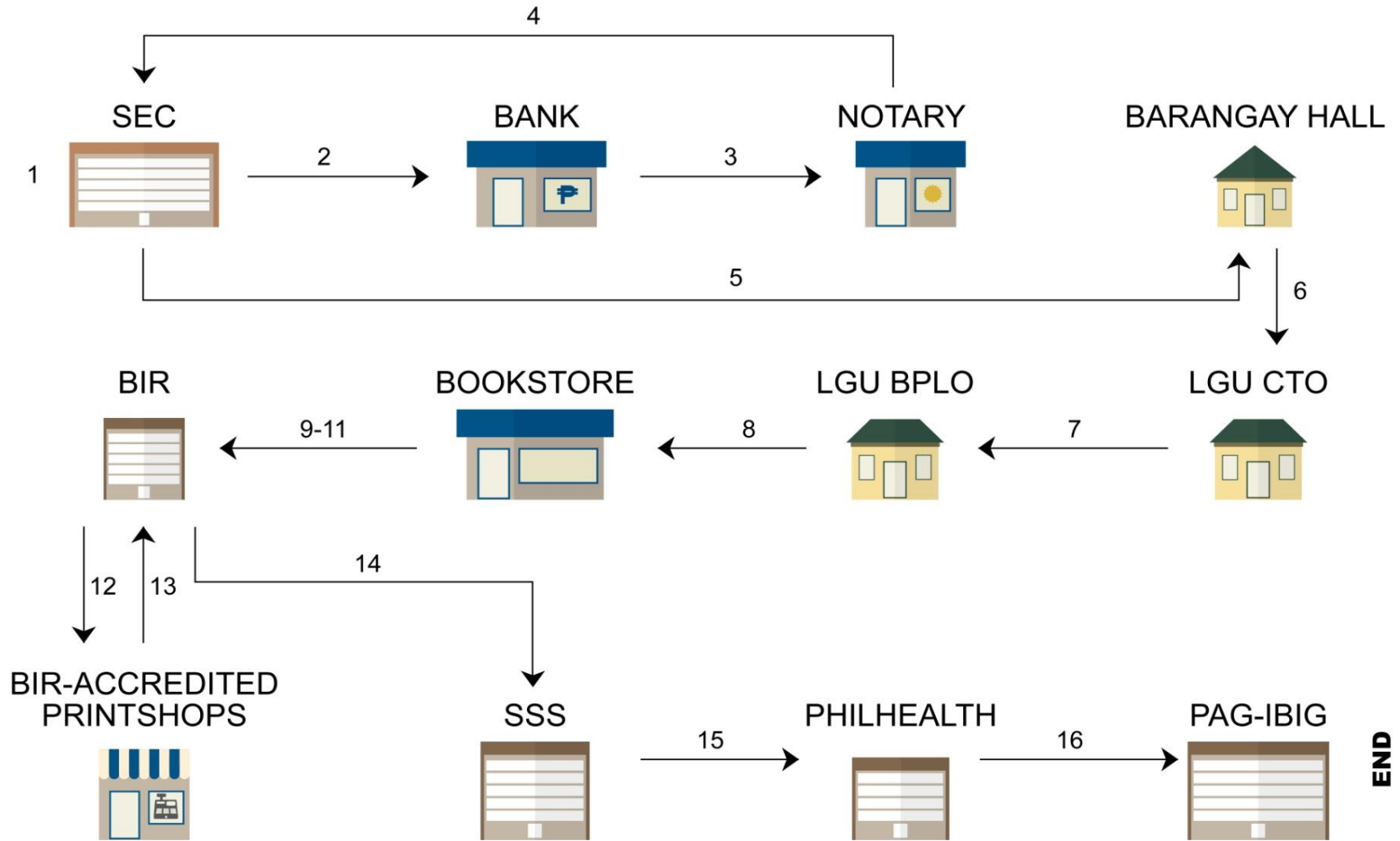

STARTING A BUSINESS

New Procedures

1

Prepare articles of incorporation, by-laws, and treasurer's affidavit signed by the incorporators for notarization.

1 DAY

2

Obtain SEC Registration Number, BIR Tax Identification Number Pag-IBIG fund, PhilHealth, and SSS Employer numbers (ERNs) at the Securities and Exchange Commission through its Integrated Business Registration System. Applicant will receive a Unified Registration Form (URF).

1 DAY

3

Obtain Barangay Clearance

1 DAY

4

Obtain Business Permit to Operate from the Business Process and Licensing Office and pay necessary fees

1-2 DAYS

5

Secure Certificate of Registration and Registration of Books of accounts at the Bureau of Internal Revenue (BIR)

1 DAY

6

A. Registration Cash Register Machine (CRM) / Point of Sale (POS)

1 DAY

B. Secure Authority to Print Receipts/ Invoices (Manual Receipts)

1-7 DAYS

can now be completed in **8** days

STARTING A BUSINESS

Agency Flowchart

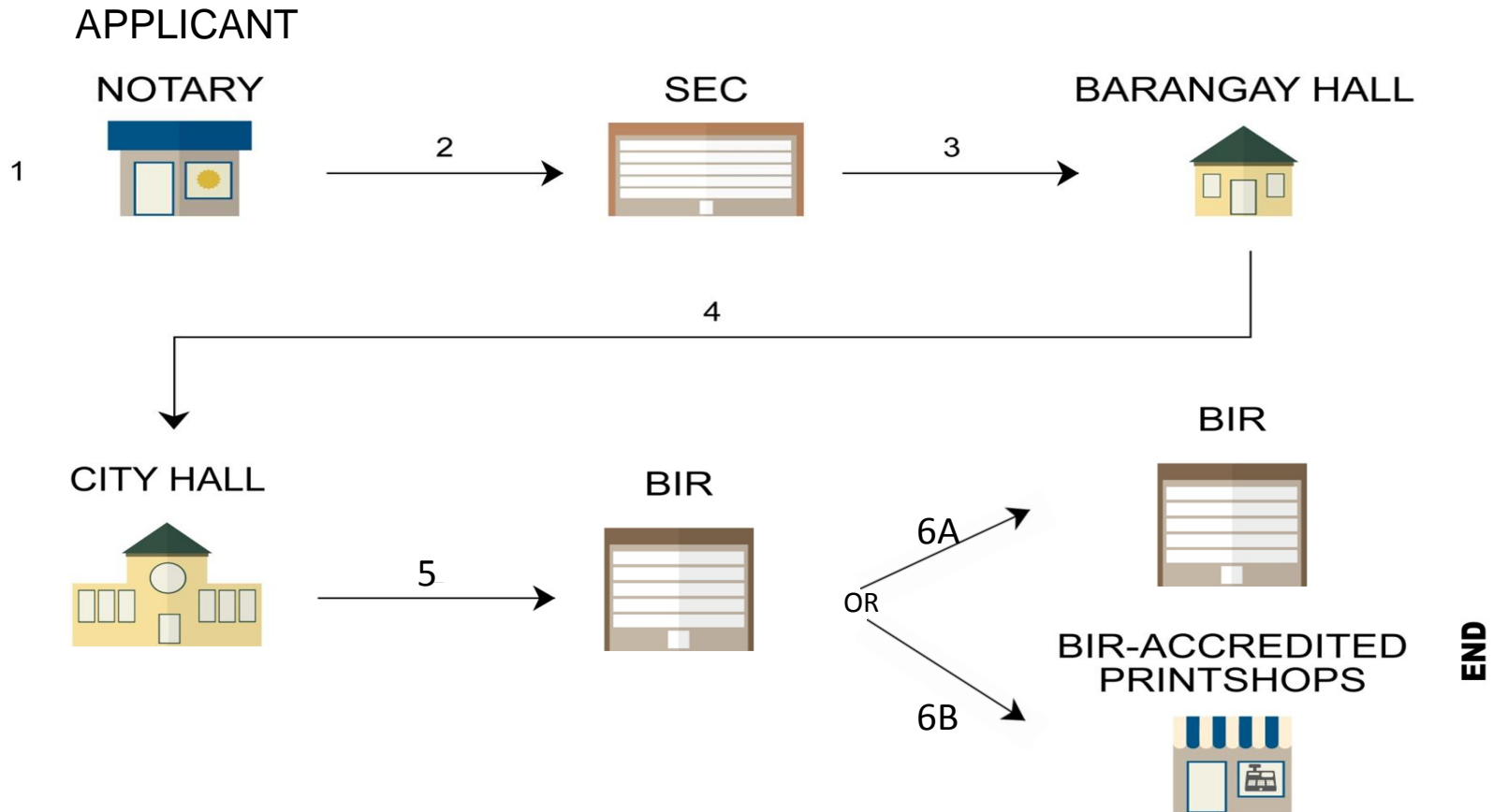

DOING BUSINESS MADE EASIER
April 21, 2016

PAYING TAXES

Old vs New Payments

FROM:

TO:

36 193

PAYMENTS HOURS

2015

13 < 193

PAYMENTS HOURS

2016



PhilHealth
Your Partner in Health



PAYING TAXES

(Social Service Contributions/Payments)

Corporate
Income Tax

Local
Business Tax

Community
Tax Certificate

Tax on
Interest

Real Property
Tax

Environmental
Tax

Stamp Duty

Employer
Compensation

Value Added
Tax

Tax on Check
Transactions

Tax on
Insurance
Contracts

SSS

Health
Insurance

Health
Insurance

Health
Insurance

Health
Insurance

Health
Insurance

Health
Insurance

Health
Insurance

Health
Insurance

Health
Insurance

Health
Insurance

Health
Insurance

Health
Insurance

Pag-IBIG
Fund

Pag-IBIG
Fund

Pag-IBIG
Fund

Pag-IBIG
Fund

Pag-IBIG
Fund

Pag-IBIG
Fund

Pag-IBIG
Fund

Pag-IBIG
Fund

Pag-IBIG
Fund

Pag-IBIG
Fund

Pag-IBIG
Fund

Pag-IBIG
Fund

36 Payments, 193 Hours

PAYING TAXES

(Social Service Contributions/Payments)

Corporate
Income Tax

Community Tax Certificate paid
jointly with Local Business Tax

Tax on
Interest

Real Property
Tax

Environmental
Tax

Stamp Duty

Employer
Compensation

Value Added
Tax

Tax on Check
Transactions

Tax on
Insurance
Contracts

SSS

Health Insurance

Pag-IBIG Fund

13 Payments, <193 Hours

PAYING TAXES

(Social Service Contributions/Payments)



No Average Daily Balance
Required**

No Average Daily Balance
Required**

Commercial Banks



Social Security System
Online Payments Available
Since 2012



Pag-IBIG Fund



PhilHealth

*e-Payment and online transactions
for Social Services
are now available.*

*Businesses with 10+ employees
may now register for e-payment services
with commercial and government banks.*

***This applies to businesses with
10+ employees effective May 2015.*

DOING BUSINESS MADE EASIER



Discovering e-Government Services

OBJECTIVES

- To increase level of awareness and promote understanding of the various government programs and services, i.e. online services
- To increase number of private sector using e-services (application, payments, filing)

OUTPUTS

- Better understanding of the usage and benefits of online services
- Identify challenges and opportunities through public/private discussion to further improve agency service to reduce process



NATIONAL COMPETITIVENESS COUNCIL



DEPARTMENT OF FINANCE



DEPARTMENT OF INTERIOR AND LOCAL GOVERNMENT



DEPARTMENT OF TRADE & INDUSTRY



BUREAU OF INTERNAL REVENUE



SECURITIES AND EXCHANGE COMMISSION



LUNGSOD NG QUEZON



SOCIAL SECURITY SYSTEM

SOCIAL SECURITY SYSTEM



PHILIPPINE HEALTH INSURANCE CORPORATION



PAG-IBIG FUND



LAND BANK OF THE PHILIPPINES



DEVELOPMENT BANK OF THE PHILIPPINES

DOING BUSINESS MADE EASIER
April 21, 2016



National Competitiveness Council

www.competitive.org.ph



Department Trade and Industry

www.dti.gov.ph



Department of Finance

www.dof.gov.ph



Department of Interior and Local Government

www.dilg.gov.ph



Bureau of Internal Revenue

www.bir.gov.ph



Securities and Exchange Commission

www.sec.gov.ph



Social Security System

www.sss.gov.ph

SOCIAL SECURITY SYSTEM



Philippine Health Insurance Corporation

www.philhealth.gov.ph



Pag-IBIG Fund

www.pagibigfund.gov.ph



Land Bank of the Philippines

www.landbank.com



Development Bank of the Philippines

www.devbnkphl.com



Quezon City Local Government

www.quezoncity.gov.ph

DOING BUSINESS MADE EASIER

PHILIPPINES MAKES DOING BUSINESS EASIER

Starting a Business simplified to 6 steps, 8 days;
 Paying Taxes (Social Service Contributions / Payments) reduced to 13 payments from 36

Starting a Business

Starting a business is now simpler due to reforms that synergize steps.
 From 16 steps and 34 days, the process has been reduced to only 6 steps and 8 days.

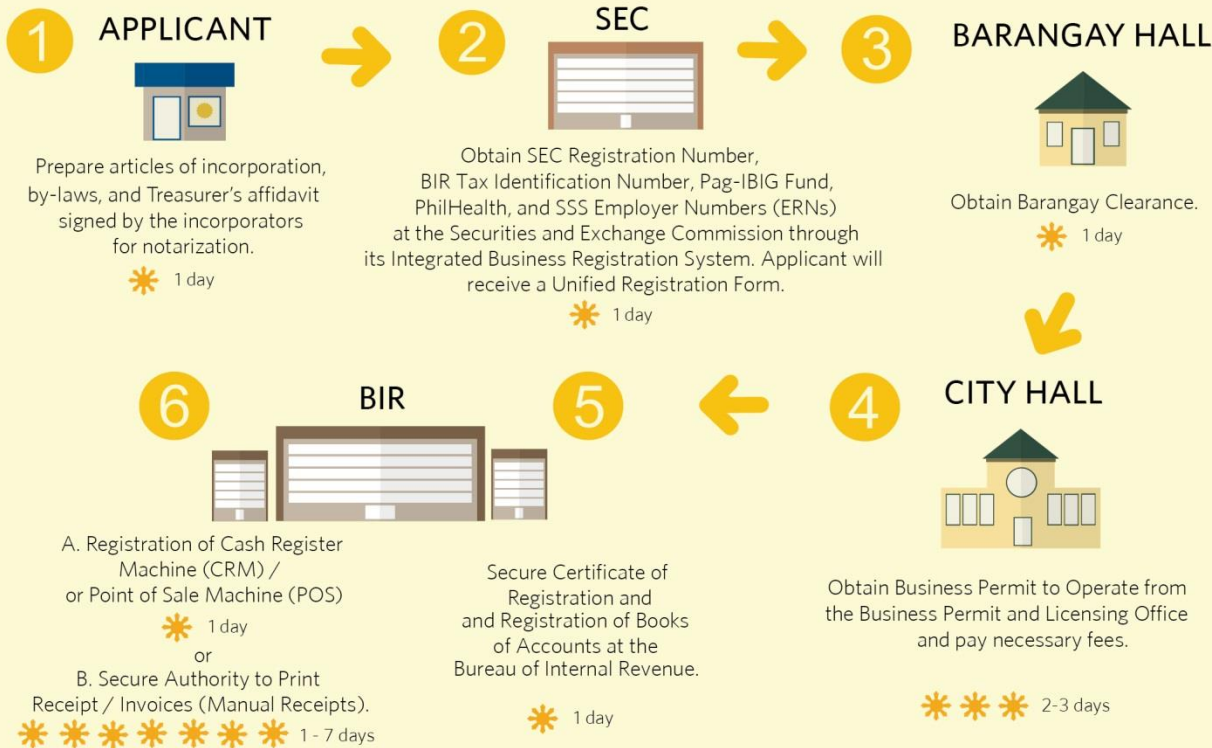

Social Service Contributions / Payments (Pag-IBIG Fund, PhilHealth, SSS)



Social Service Contributions made easier through technology, reducing the number of payments from 36 to 13.



Accessible and convenient online payment

- Through commercial and government banks (i.e. Land Bank of the Philippines & Development Bank of the Philippines)
- To offer **"No Average Daily Balance"** for corporate accounts made available to employers in LBP & DBP.



Boosting of e-Government facilities (Pag-IBIG Fund, PhilHealth, & SSS)

- Through regular conduct of capacity building programs on e-Gov services.
- Through active stakeholders engagement.

Made possible through:



THANK YOU



fb.com/compete.philippines



[@NCC_ph](https://twitter.com/NCC_ph)



www.competitive.org.ph



admin@competitive.org.ph